

APEM

0 06

8000 SERIES - RUGGED SWITCH JOYSTICKS

ONE OR TWO AXES, SINGLE STEP OR PROGRESSIVE SWITCHING

UPTO 1AMP OPERATION GOLD PLATED CONTACTS

OPTIONAL CENTRE DETECT MICROSWITCH

WIDE RANGE OF HANDLE OPTIONS

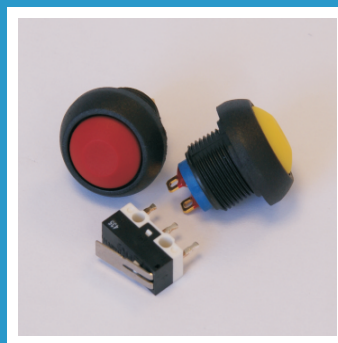

8000 SERIES - RUGGED SWITCH JOYSTICKS

PRODUCT DESCRIPTION

GENERAL DESCRIPTION

The 8000 Series is a family of rugged switch joysticks. Based on the proven mechanics of the 9000 Series, the 8000 Series utilises high quality microswitches to provide a range of possible outputs, including the option of progressive switching on a single axis for dual speed control.

MICROSWITCHES

The 8000 Series utilises industrial quality microswitches with changeover contacts. As standard, the switches are rated to a maximum of 1 Amp, and have gold plated contacts for reliable switching at low current levels. Please note when specifying a joystick with a push button handle the characteristics of the push button will be different from the microswitches. Please refer to Apem for full details and characteristics of your chosen configuration.

SWITCHING OPTIONS

The following configurations are available as standard :

Single Axis - Single Pole : One switch will actuate as the joystick moves to either end of its axis.

Single Axis - Double Pole : Two switches will actuate as the joystick moves to either end of its axis.

Single Axis - Progressive : One switch will actuate after 8 degrees of movement, with a further switch actuating after another 10 degrees of movement, in either direction.

Single Axis - Progressive with detents : As above, but with a mechanical detent at the point of the first switch actuation in each direction.

Dual Axes - Single Pole : One switch in each of the four positions; North, South, East and West.

Dual Axes - Double Pole : Two switches in each of the four positions; North, South, East and West.

Note : Double Pole switching is designed such that both switches in any given position trigger nominally together.

Many configurations are also available with a further microswitch actuating when the joystick is at centre, for centre detection purposes.

GUIDED FEEL

8000 Series joysticks may also be specified with guided feel. A joystick with guided feel moves more readily towards the poles (North, South, East and West) and whilst it can still move away from the poles, the force required to do so is greater. Unless specified otherwise, joysticks are supplied as standard without guiding. This standard configuration allows the user to move the joystick anywhere within the limiter with the same force and without any bias.

CABLE SPECIFICATION

As standard the joysticks are supplied utilising the normally open contacts of the microswitches. For connection to the normally closed contacts, please specify this as part of your special modification.

Cable information may be subject to specification, please refer to Apem for details.

Connectors and custom looms may be factory fitted upon request.

14/0.12 - Fourteen strands of 0.12mm diameter tinned annealed copper wire PVC insulated to a nominal OD of 1mm.			
Red	: Common	Black	: First Switch East
Blue	: Second Switch West	Yellow	: Second Switch East
Green	: First Switch West	Purple	: First Switch South
Orange	: Second Switch North	White	: Second Switch South
Brown	: First Switch North	Grey	: Centre Detect Switch
7/0.127 - Seven strands of 0.127mm diameter tinned copper wire ETFE insulated, to a nominal OD of 0.7mm			
Orange	: First Push Button (Top of Handle)	Green	: Second Push Button
All 8000 Series are supplied with 150mm of twisted cable harness, with tinned ends.			

Note: The company reserves the right to change specifications without notice.

8000 SERIES - RUGGED SWITCH JOYSTICKS

PRODUCT CONFIGURATION

STANDARD OPTIONS

The 8000 Series is available with a range of standard options, to specify your joystick, simply choose one option from each column. An example is shown below.

8	A	A	2	A	C	6	5	00
SERIES	AXES	SWITCHING	CENTRE DETECT	LIMITER	HANDLE	BEZEL	GAITER	MODIFIER
8000 (8)	One (A) Two (B)	Single Axis Single Pole (A) Single Axis Double Pole (B) Single Axis Progressive with Detents (C) Single Axis Progressive (D) Two Axes Single Pole (E) Two Axes Double Pole (F)	Fitted (See note 1) (1) Not fitted (2)	Single Axis (A) Cross (C) Diamond (D) Round (R) Square (S)	Round (C) Cylindrical (D) Conical (E) Conical (G) Push Button Tactile (K) Skirted (Q) Two Button Multifunction (X)	Not supplied (0) Circular (4) Square (6)	Standard (5)	None (00) Guided Feel (See Note 2) (20)

NOTES

1) The additional centre detect switch is not available on joysticks with progressive switching.

2) Guided feel is only available on two axes joysticks.

Further non standard options including custom handles, special limiters and detents are available. Please refer to Apem.

BEZEL OPTIONS

For drop in mounting, please specify bezel option 6. For sub-panel mounting, no bezel is necessary, unless the gaiter is required to seal to the face of the panel in which case bezel option 4 should be specified.

SPRINGING

As standard 8000 Series are offered sprung to centre. The standard spring force requires 1.3N (nominally) to off-centre the joystick. The 8000 Series may be specified with a lighter spring (1N), or a stronger spring (1.6N)

Note: Forces quoted are subject to exact joystick configuration and are provided as a guide only.

TECHNICAL SPECIFICATION

All parameters and dimensions shown maybe subject to specification, please refer to Apem for details.

Mechanical Life Cycles	: >1 Million Mechanical Operations	Maximum Voltage	: 125 VAC
Current Rating	: To 1A	Switch Contacts	: Gold Plated
Weight	: 90 grams	Above Panel Seal	: IP 65
Operating Deflection	: +/-18 Degrees	Body Material	: Glass Reinforced ABS
Shaft Diameter	: 5mm	Gimbal Pivot	: Acetal & Hardened Steel
Shaft Material	: Stainless Steel	Other Materials	: Brass, Acetal, Nylon
Gaiter	: Neoprene	Temperature Range	: -25C to 80C

8000 SERIES - RUGGED SWITCH JOYSTICKS

SWITCHING CONFIGURATIONS

SINGLE AXIS CONFIGURATIONS

SWITCHING OPTION A

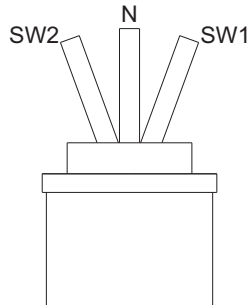

N = Neutral

One switch will actuate as the joystick moves away from centre in either direction.

SWITCHING OPTION B

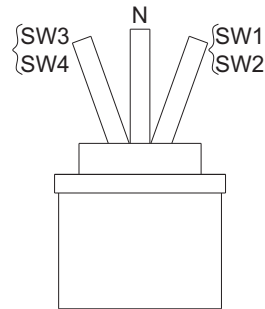

N = Neutral

Two switches will actuate as the joystick moves away from centre, in either direction.

SWITCHING OPTION C

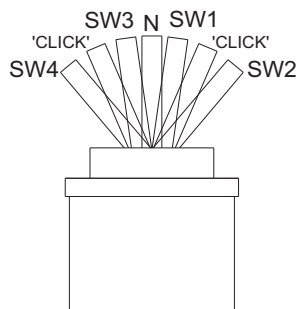

N = Neutral

As per option D, but with a mechanical detent between actuation of the first and second switch.

SWITCHING OPTION D

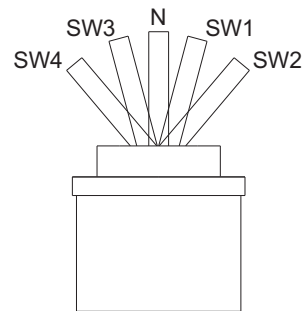

N = Neutral

One switch will actuate after 50% of travel, with a further switch at the end of travel, in either direction.

TWO AXES CONFIGURATIONS

SWITCHING OPTION E

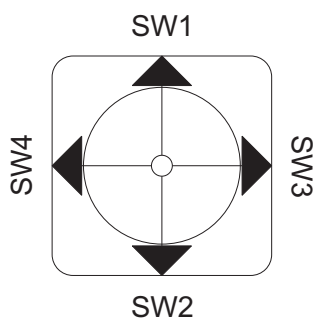

One switch will actuate in each of the four directions ; North, South, East & West.

SWITCHING OPTION F

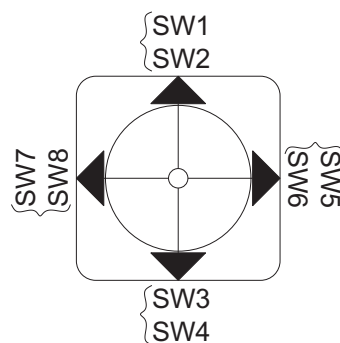

Two switches will actuate in each of the four directions ; North, South, East & West.

8000 SERIES - RUGGED SWITCH JOYSTICKS

USEFUL DIMENSIONS

GENERAL DIMENSIONS

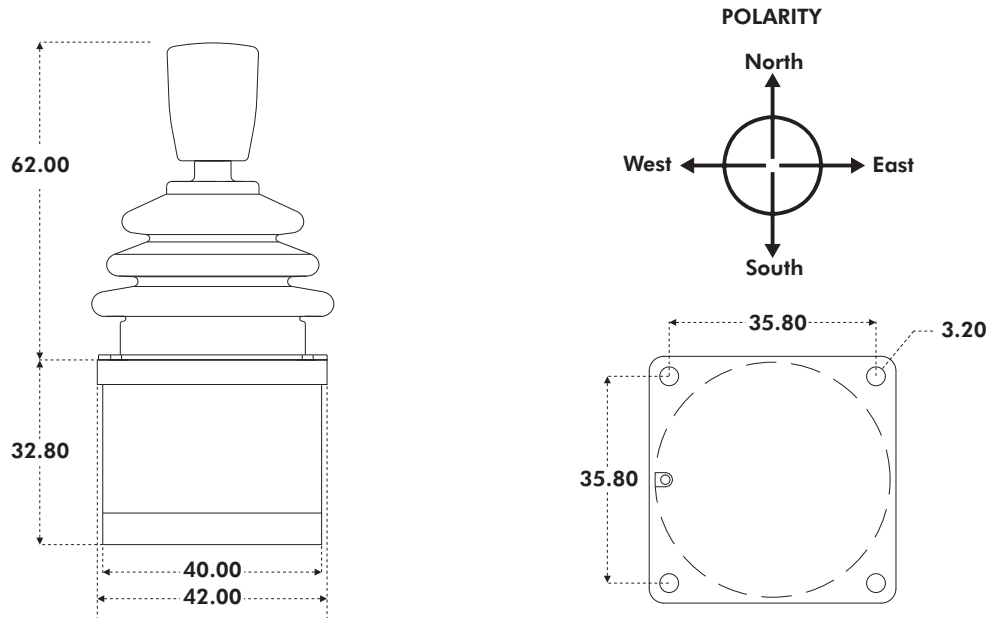

DROP IN MOUNTING - PANEL CUT-OUT & MOUNTING INSTALLATION

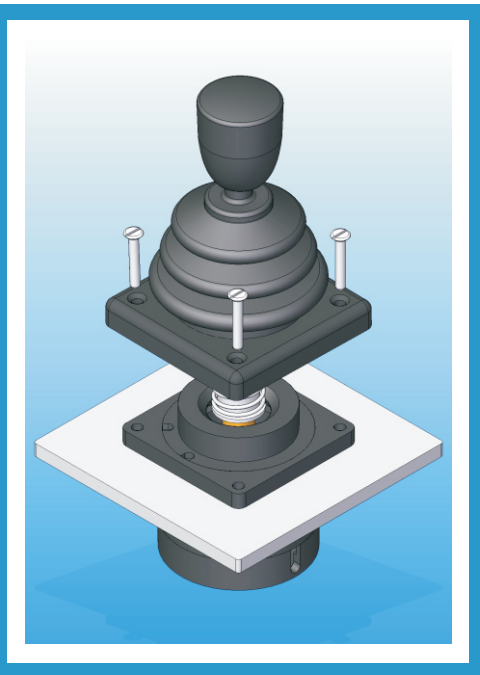

MOUNTING CUT-OUT

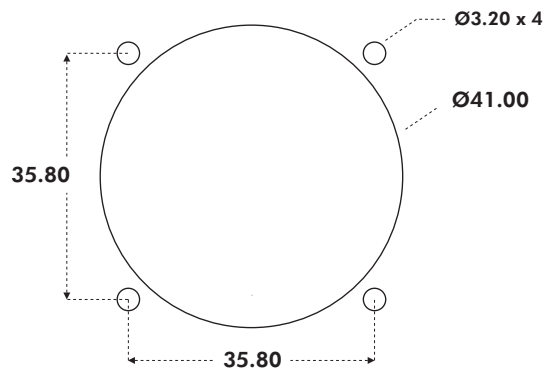

The joystick is dropped into the panel cut-out. For panel thickness of <math>< 3\text{mm}</math>, M3 x 16 countersunk machine screws are recommended.

Note: The dimensions shown are for a generic 8000 Series with the conical E type handle. For specific dimensions of this or any other configuration please refer to Apem.

8000 SERIES - RUGGED SWITCH JOYSTICKS

USEFUL DIMENSIONS

MOUNTING OPTION A - PANEL CUT-OUT & MOUNTING INSTALLATION

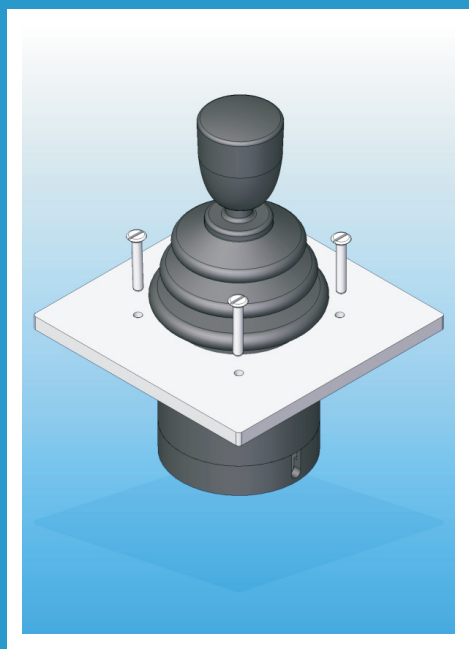

MOUNTING CUT-OUT

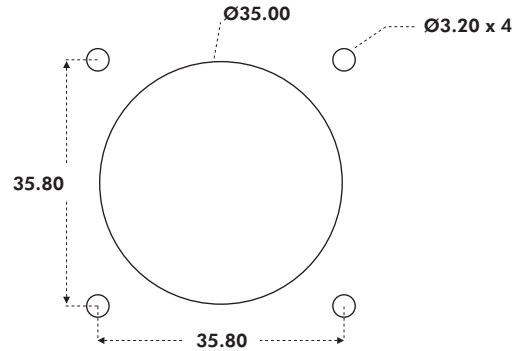

When mounted this way the panel acts as the bezel and no separate bezel is needed. M3 machine screws are recommended.

MOUNTING OPTION B - PANEL CUT-OUT & MOUNTING INSTALLATION

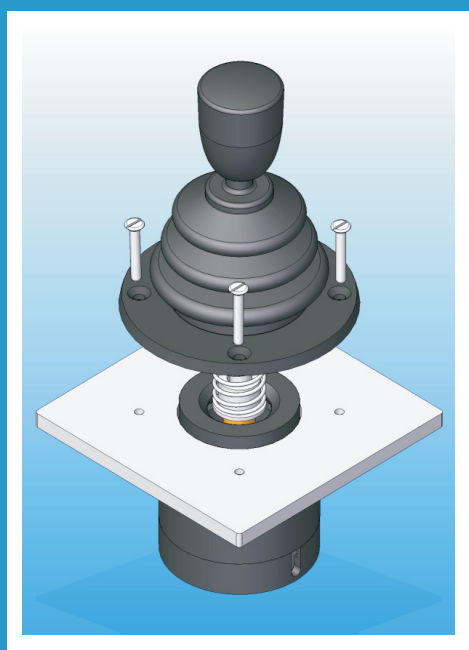

MOUNTING CUT-OUT

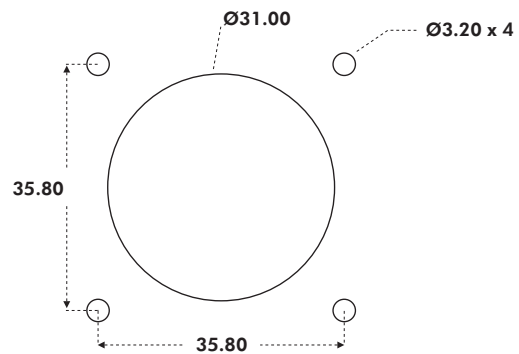

The joystick flange is mounted beneath the panel and the base of the gaiter must be brought through the panel cut-out and held in place with the circular bezel. For panel thicknesses of 3mm, M3 x 16 countersunk machine screws are recommended.

Note: When sub panel mounting, great care should be taken not to damage the gaiter, or any of the mechanism under the gaiter. All panel cut-outs should be free from sharp edges and swarf that may damage the gaiter.